

# PHYSICS 208 Final Exam

Spring, 2010

*Do not fill out the information  
below until instructed to do so!*

Name: \_\_\_\_\_

Signature: \_\_\_\_\_

E-mail: \_\_\_\_\_

Section Number: \_\_\_\_\_

- 
- No calculators are allowed in the test.
  - Be sure to put a box around your final answers and clearly indicate your work to your grader.
  - **All work must be shown to get credit for the answer marked. If the answer marked does not obviously follow from the shown work, even if the answer is correct, you will not get credit for the answer.**
  - Clearly erase any unwanted marks. No credit will be given if we can't figure out which answer you are choosing, or which answer you want us to consider.
  - Partial credit can be given only if your work is clearly explained and labeled. Partial credit will be given if you explain which law you use for solving the problem.

Put your initials here after reading the above instructions:

For grader use only:

Problem 1 (5) \_\_\_\_\_

Problem 2 (15) \_\_\_\_\_

Problem 3 (15) \_\_\_\_\_

Problem 4 (19) \_\_\_\_\_

Problem 5 (18) \_\_\_\_\_

Problem 6 (18) \_\_\_\_\_

Problem 7 (15) \_\_\_\_\_

Total (105) \_\_\_\_\_

**Problem 1: (5 points)**

Write Maxwell's equations in the integral form.

**Problem 2: (15 points)**

The circuit below was put together a long time ago so that the steady state has been reached.

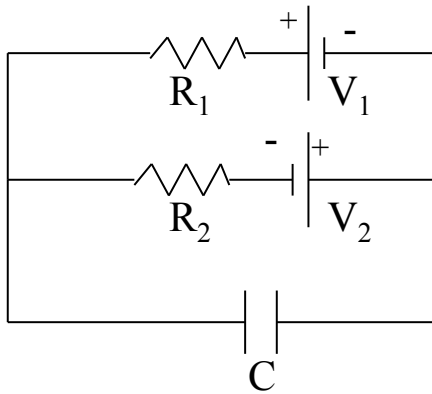

Find all currents, voltage drops across the resistors, and the charge on the capacitor plates.

**Problem 3: (15 points)**

There is a charge  $Q$  uniformly spread over a quarter of circle of radius  $R$  centered at the origin. There is also a point positive charge  $q_0$  located at the origin. Find a force acting on charge  $q_0$ .

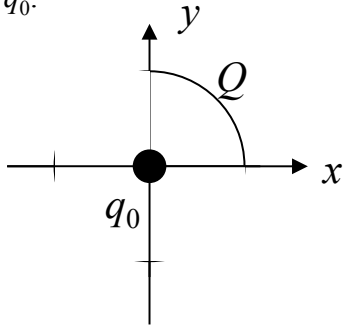

**Problem 4: (19 points)**

In the circuit below the switch has been **closed** for a long time.

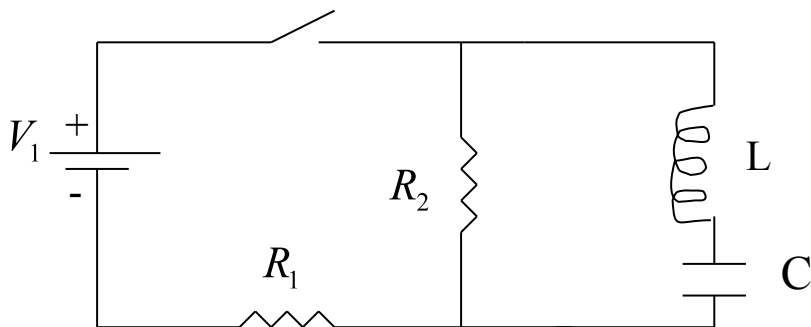

a) If at  $t=0$  the switch is opened, what differential equation **can be solved** to find  $Q$ , the charge on the capacitor, as a function of time? (Assume that  $L$  includes the self-inductance). **Do not solve the equation.**

b) Find the charge on the capacitor plates as a function of time if inductance  $L$  can be ignored. Plot  $Q(t)$  schematically.

c) Find the current through  $R_2$  as a function of time if capacitance  $C$  can be ignored.  
Plot the current as a function of time schematically.

**Problem 5: (18 points)**

A vertically oriented loop with resistance  $R$ , length  $l$  and width  $w$ , falls from a region where the magnetic field of a given magnitude  $B$  is horizontal, uniform, and pointing into the page as shown in the Figure.

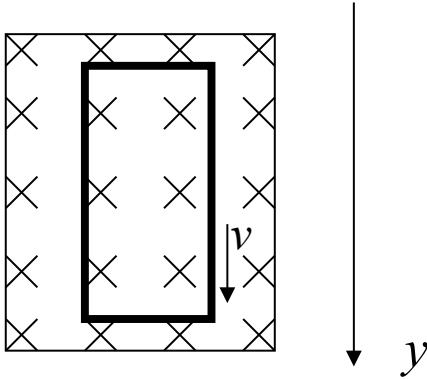

- a) Find the current in the loop as a function of the velocity  $v$  if the loop is falling down but is completely within the region having magnetic field  $\vec{B}$
  
- b) Find the current (magnitude and direction) in the loop as a function of the velocity of the loop  $v$  once the lower segment leaves the region with magnetic field. (Note that the positive  $y$  direction is down). Ignore the self-inductance.
  
- c) If the loop has mass  $m$  and is initially at rest, find the terminal speed of the loop assuming that the terminal speed is reached while the upper segment of the loop is still in the magnetic field. Ignore the self-inductance.

**Problem 6: (18 points)**

a) Consider two concentric conducting spherical shells with inner radius  $A$  and outer radius  $B$ . Find capacitance of the system.

b) The same spherical capacitor as in part a) is connected to a generator. The voltage between the capacitor's plates is changing according to  $V_0 \cos \omega t$ . Find the displacement current through an a sphere of an arbitrary radius  $r$ ,  $A < r < B$ , in terms of capacitance found in part a).



### Problem 7: (15 points)

Coaxial cable: Consider an infinitely long cylindrical conductor carrying a current  $i$  spread uniformly over its cross section and a cylindrical conducting shell around it with a current  $i$  flowing in the opposite direction. It is uniformly spread over the cross section of the shell.

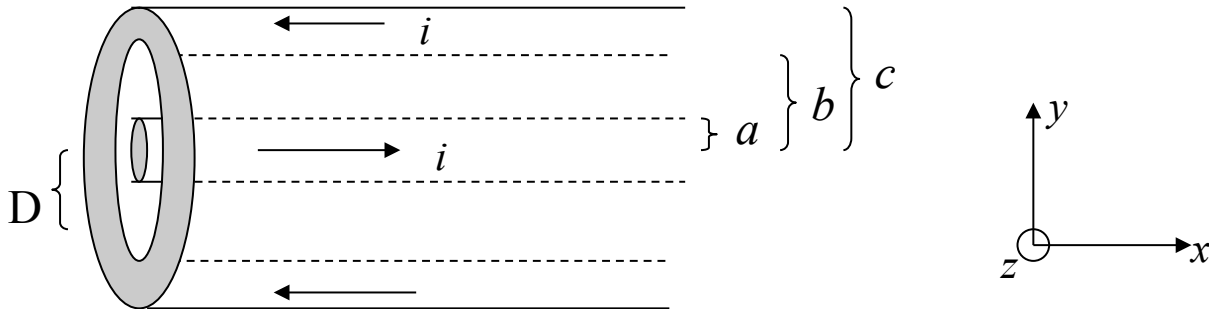

a) Find the magnetic field everywhere ( $r < a$ ;  $a < r < b$ ;  $b < r < c$ ;  $r > c$ )

b) A negatively charged particle, charge  $-q_0$ , is moving at the distance  $D$  from the center of the wire (see the Figure) parallel to the axis of the wire with a constant velocity  $v_0$  positive in  $+x$  direction. Find the force (magnitude and direction) acting on the particle due to the magnetic field.