

PHYSICS 208 Final Exam

Spring, 2011

*Do not fill out the information
below until instructed to do so!*

Name: _____

Signature: _____

E-mail: _____

Section Number: _____

-
- No calculators are allowed in the test.
 - Be sure to put a box around your final answers and clearly indicate your work to your grader.
 - **All work must be shown to get credit for the answer marked. If the answer marked does not obviously follow from the shown work, even if the answer is correct, you will not get credit for the answer.**
 - Clearly erase any unwanted marks. No credit will be given if we can't figure out which answer you are choosing, or which answer you want us to consider.
 - Partial credit can be given only if your work is clearly explained and labeled. Partial credit will be given if you explain which law you use for solving the problem.

Put your initials here after reading the above instructions:

For grader use only:

Problem 1 (5) _____

Problem 2 (13) _____

Problem 3 (18) _____

Problem 4 (18) _____

Problem 5 (18) _____

Problem 6 (18) _____

Problem 7 (15) _____

Total (105) _____

Problem 1: (5 points)

Write Maxwell's equations in the integral form.

Problem 2: (13 points)

Two charges, $+Q$ and $-2Q$, are separated by a distance d . Calculate x and y components of the electric field at point P which is a distance b above the negative charge.

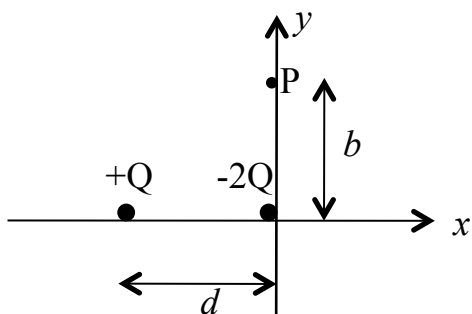

Problem 3: (18 points)

A capacitor with capacitance C is charging by a battery V through a resistor R . The switch is closed at $t=0$. The self-inductance of the circuit can be ignored.

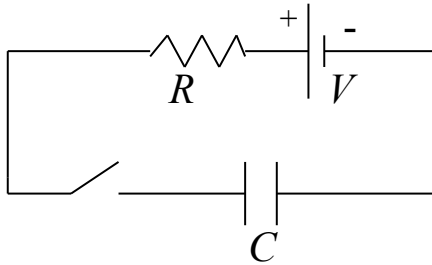

a) Find the charge on the capacitor as a function of time.

b) Find the current i into the plates and the displacement current. Calculate the displacement current through the flux of the electric field. Area of the plates is A .

Problem 4: (18 points)

- a) A non-uniform, but spherically symmetric, distribution of charge has a charge density $\rho(r)$ given as follows:

$$\rho(r) = \rho_0(1 - 4r/3R) \quad \text{for } r \leq R$$

$$\rho(r) = 0 \quad \text{for } r \geq R$$

where ρ_0 is a positive constant. Find the electric field everywhere.

- b) Consider a parallel plate capacitor with area A and distance d between the plates. Find capacitance of the system.

Problem 5: (18 points)

a) In the circuit below the switch has been **closed** for a long time so that steady state has been reached. Find the currents through resistors R_1 and R_2 and the charges on the capacitors.

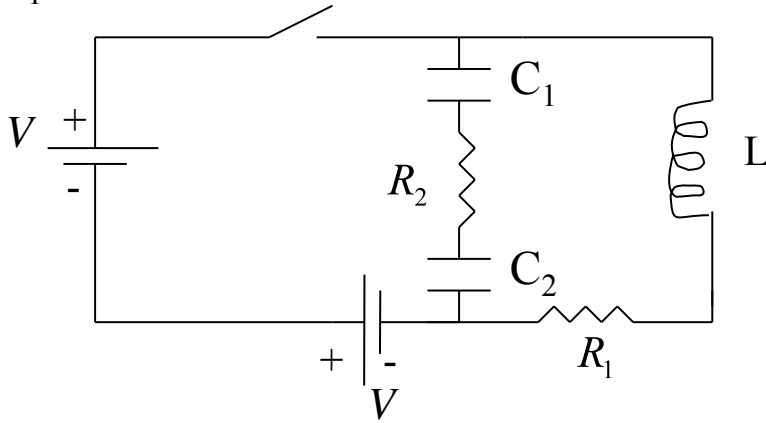

b) If at $t=0$ the switch is opened, what differential equation **can be solved** to find Q , the charge on the capacitor C_1 , as a function of time? (Assume that L includes the self-inductance). Derive the equation (show your work). **Do not solve the equation.**

Problem 6: (18 points)

A constant current i_0 flows in the long wire, in the direction shown. A loop with resistance R has dimensions shown in the figure at time $t=0$. At that instant someone starts expanding the loop by pulling it as shown, so that width a is increasing at a constant speed v , $a(t)=a_0+vt$, a_0 is a given constant, whereas height b stays constant.

a) Find the magnitude and direction of the current induced in the loop if self-inductance can be ignored.

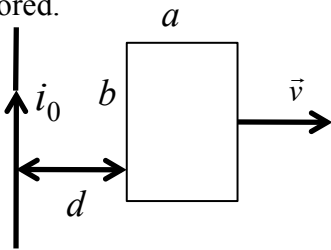

b) Derive the equation that can be solved to find the magnitude of the current induced in the loop if self-inductance of the loop is L . Do not solve the equation.

d) Find the magnitude and direction of the current induced in the loop if the loop is moving **up** at constant speed v instead of expanding to the right. (You can ignore the self inductance).

Problem 7: (15 points)

A very long straight wire has a loop of radius R in the middle. Current i flows down the straight part of the wire, and then around the loop, and then down the rest of the straight part. Calculate the magnetic field at the center of the loop.

