

PHYSICS 208 Final Exam

Spring, 2015

*Do not fill out the information
below until instructed to do so!*

Name: _____

Signature: _____

E-mail: _____

Section Number: _____

-
- No calculators are allowed in the test.
 - Be sure to put a box around your final answers and clearly indicate your work to your grader.
 - **All work must be shown to get credit for the answer marked. If the answer marked does not obviously follow from the shown work, even if the answer is correct, you will not get credit for the answer.**
 - Clearly erase any unwanted marks. No credit will be given if we can't figure out which answer you are choosing, or which answer you want us to consider.
 - Partial credit can be given only if your work is clearly explained and labeled. Partial credit will be given if you explain which law you use for solving the problem.

Put your initials here after reading the above instructions:

For grader use only:

Problem 1 (5) _____

Problem 2 (20) _____

Problem 3 (18) _____

Problem 4 (18) _____

Problem 5 (20) _____

Problem 6 (14) _____

Problem 7 (10) _____

Total (105) _____

Problem 1: (5 points)

Write Maxwell's equations in the integral form.

Problem 2: (20 points)

A spherical insulating shell, inner radius A and outer radius B , has charge uniformly spread throughout the volume with charge density ρ_0 . It is surrounded by a conducting spherical shell of inner radius C and outer radius D .

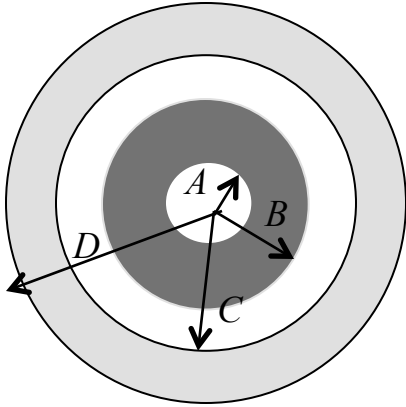

a) Find the electric field at

1) $r < A$

2) $A < r < B$

3) $B < r < C$

4) $C < r < D$

5) $r > D$

b) Find the difference in electric potential between $r = B$ and $r = 2D$: $V(2D) - V(B)$.

c) Instead a spherical insulating shell, inner radius A and outer radius B , has charge spread non-uniformly so that the charge density is $\rho = cr$, c is a constant. This density is not a function of angle. Find the electric field at $A < r < B$.

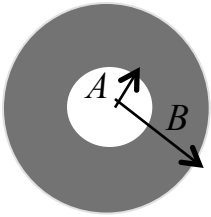

Problem 3: (18 points)

A square loop of wire with resistivity ρ and cross-sectional area a , has sides of length L (see the figure). It is placed in the magnetic field directed out of the page; its magnitude is given by $B = \alpha t^2 y$ where α is a known constant, t is time.

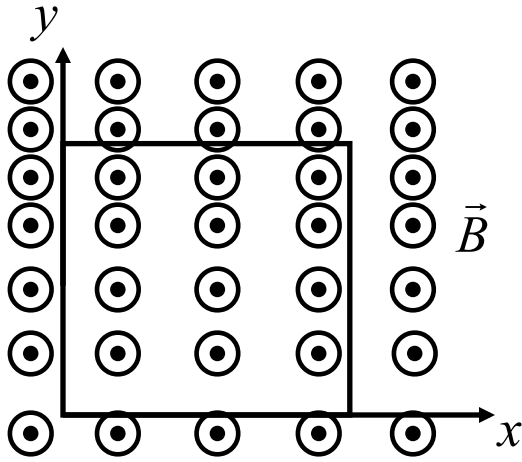

- a) Find the direction of the current in the loop.
Explain your answer within this box:

- b) Find the current induced in the loop. Ignore self-inductance.

Problem 4: (18 points)

In the circuit below the switch has been in the position A for a long time.

a) Find the current and charge on the capacitor.

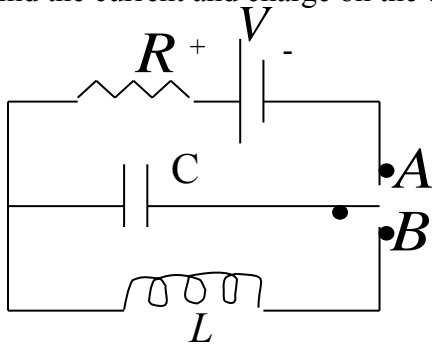

b) At $t=0$ the switch is moved to the position B . Starting from some famous law, derive the equation that can be solved to find the charges on the capacitor as a function of time.

c) Find the charge on the capacitor as a function of time.

Problem 5: (20 points)

A rectangular frame of conducting wire has negligible resistance and width w and is held vertically in a magnetic field of magnitude B , as shown in the figure. A metal bar with mass m and resistance R is placed across the frame, maintaining contact with the frame. The bar is allowed to fall freely along this frame starting from rest. Neglect friction between the wires and the metal bar.

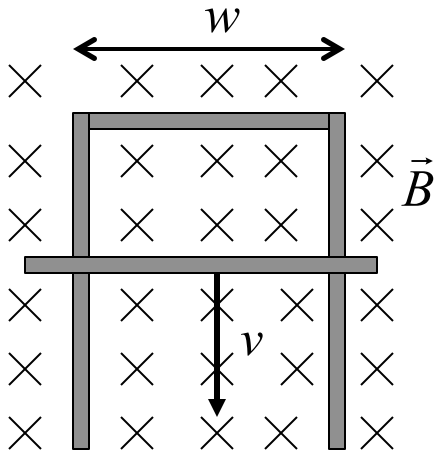

- a) Find the direction of the current in the loop.
Explain your answer within this box:

- b) Find the current in the loop in terms of velocity of the bar. Neglect self-inductance.

- c) Derive the equation that could be solved for the current in the loop if the self-inductance is not ignored but has a magnitude of L . Do not solve the equation.

d) Solve for the current in the wire if the self-inductance can be assumed to have a constant value L and $i(t = 0) = 0$.

e) Derive an expression for the terminal velocity of the bar. Neglect self-inductance.

Problem 6: (14 points)

Wire 1 consists of a circular arc and two radial lengths. It carries current i_1 in the direction indicated. Wire 2, shown in cross section, is long, straight, and perpendicular to the plane of the figure. Its distance from the center of arc is equal to the radius R of the arc, and it carries a current i_2 which is out of the page. Find the total magnetic field at the center of the arc.

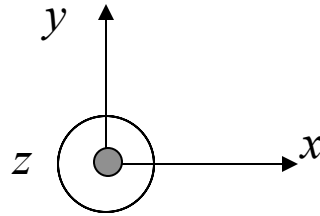
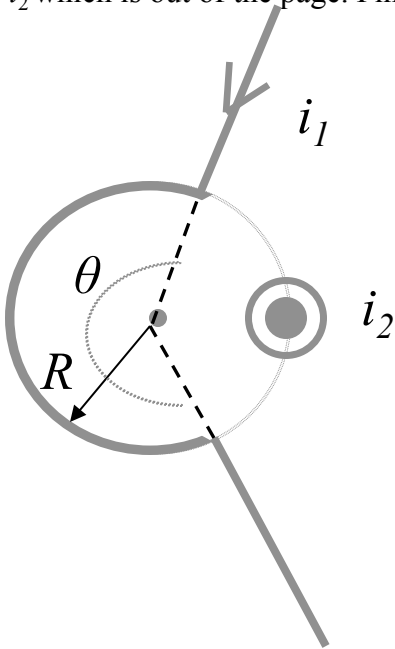

Problem 7: (10 points)

The magnitude of the electric field between the two circular parallel plates is

$$E = \alpha - \beta t$$

where α and β are constants. At $t=0$, \vec{E} is upward. The plate area is A . For $t \geq 0$, find the displacement current between the plates. Is the direction of the induced magnetic field clockwise or counterclockwise in the figure? Explain your answer.

